



Oil Service Units

Cleanline portable light

FA 014

- Easy filling and cleaning
- Compact design
- Comfortable handling

Cleanline portable light – quick, simple and compact

With the oil service unit FA 014 hydraulic or lubricating systems can be easily filled or cleaned.

Dirt-holding capacity

Values in g test dust ISO MTD according to ISO 16889

Hydraulic fluids

Mineral oil and biodegradable fluids (HEES and HETG, see info sheet 00.20). Other fluids on request.

Temperature range of fluids /

Viscosity range

0 °C...+60 °C

Continuous operation min.: 15 mm²/s

Continuous operation max.: 250 mm²/s

Short-term operation max.: 400 mm²/s

Ambient temperature range

0 °C...+50 °C

Suction height

max. 1,5 m

Operating pressure

max. 4 bar

Clogging indicator

Manometer

Order no.	FA 014-1600
Nominal flow rate	16 l/min
Filter fineness	12 E ($\beta_{12(c)} = 200$)
Dirt-holding capacity	45 g
Operating voltage / frequency	1 ~ 230 V / 50 Hz
Power / Protection type	0,45 kW / IP 55
Replacement element order no.	V7.1210-06
Weight	16 kg

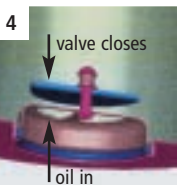
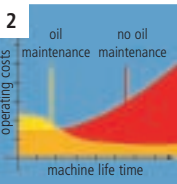

1. Compact design

The compact design allows easy access to the oil tank. FA 014 comes ready to connect, with hose packages.

2. Economical

Efficiency through ARGO-HYTOS Fluid Management systems. After just a short time your investments will be amortized due to longer service intervals and increase of machine availability.

3. User-friendly filter element change

Optimal operator handling has been a key feature in the development of FA 014. No extra tools are needed to open the housing and the filter element can be pulled out through the hang-in technique.

4. Maintenance-free filter housing thanks to a clever filter element technique

On the bottom of the from inside to outside flown through filter elements there is a dirt retention valve. If the filter element is pulled out of the filter housing with the cover, the dirt retention valve will close. Sedimented dirt is removed from the housing with the filter element.

5. Quality in detail

The EXAPOR® fine element is the heart of the FA 014. High cleanliness levels protect hydraulic systems against dirt during the oil filling process.

For filling and cleaning of hydraulic or lubricating systems with high demands to the oil cleanliness we recommend the ARGO-HYTOS oil service unit Cleanline portable FA 016.

Dimensions

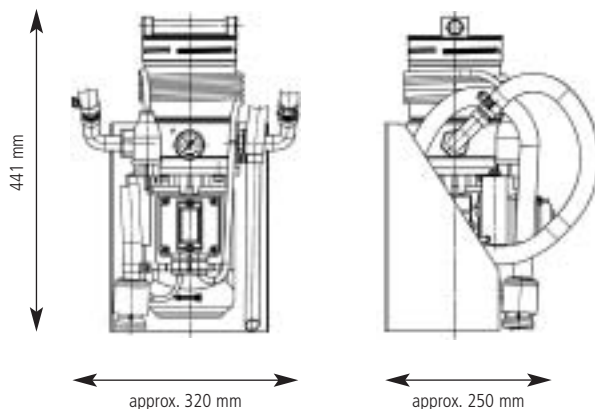

Hydraulic symbol

