



## Oil Service Units

### ECOLINE

#### UM 045 / UMP 045 / UMPC 045

- Easy filling, cleaning and pumping over
- Unbeatable ergonomics, optimal handling
- High filtration performance
- May be combined with portable oil diagnostic system optionally
- Optionally with integrated particle monitor

**Oil service – simple , quick and compact**



## **ECOLINE**

### **Easy, compact and ergonomic**

With ECOLINE hydraulic or lubrication systems can simply be filled, cleaned or fluid can be pumped over without using the filter function. The ergonomic design allows simple handling also on closest work space.

### **Protection of components through ultra-fine filtration**

The EXAPOR® ultra-fine element is the heart of the ARGO-HYTOS oil service unit ECOLINE. High separation efficiency guarantees excellent cleanliness levels and thereby highest protection of components. The high dirt holding capacity of the EXAPOR® ultra-fine elements allows economic operation of the ECOLINE.

## **ECOLINE base model - UM 045**

The UM 045 is delivered equipped with hoses, and is ready to connect. For easy transport, electrical cables, as well as suction and return hose, are mounted with support fixtures on the carrier device. The tool can be stowed in the basket of the carrier device.

... with integrated particle monitor



**NEW!** Now with integrated particle monitor!

## ECOLINE with integrated particle monitor UMPC 045

The integrated particle monitor in the UMPC 045 permanently monitors oil cleanliness during the filtering process.

Cleanliness class monitoring can be selected for "cleaning" or "filling" with a change-over cock. The ordinal number of the selected particle size, 4, 6, 14, or 21  $\mu\text{m}$  is shown on the display of the particle monitor in accordance with ISO 4406:1999.

Data can be transmitted to a computer via an RS 232 interface, and thus the gradient can be shown graphically or in table form, and tracked. If data transmission to a computer is not possible, then up to 500 measurements are stored in a ring buffer and can be retrieved at a later point in time.

The basic configuration of the particle monitor in the UMPC 045 can be adapted with PALM Organizer, or alternatively it can be adapted via a PC with infrared interface. A CD with the software necessary for data transmission is included in delivery.

... with programmable oil diagnostic system



## ECOLINE with oil diagnostic system PODS Pro – UMP 045

ECOLINE in the UMP 045 version, is equipped with adapters for the portable ARGO-HYTOS oil diagnostic system PODS Pro. With few turns of your hand PODS Pro can be attached to the ECOLINE and is immediately ready for operation. Oil purity is monitored in the bypass with PODS Pro when cleaning hydraulic systems.

In conjunction with PODS Pro (Portable Oil Diagnostic System), ECOLINE makes it possible to verify the cleaning efficiency. Selective cleaning is possible by input of the desired cleanliness class. After reaching the programmed target cleanliness class the complete unit UMP 045 and

PODS Pro turns off. In addition with PODS Pro the cleanliness class can be determined online on high-pressure lines or per bottle sampling in accordance with all standard cleanliness classifications.

The intelligent software also enables the implementation of cleaning processes that are controlled by the level of fluid contamination.

The determined cleanliness classes can be documented on a print-out on-site, indicated on the PODS Pro itself at any time or can be downloaded on an external memory later on by using the special PODSWare.

The PODSWare enables the user to issue a purity certificate with individual labels.

# Description

## Cleaning Speed

The cleaning speed depends on the efficiency of the filter elements ( $\beta_x(c)$ ), the nominal volume flow ( $Q_{\text{nominal}}$ ) and the oil volume ( $V_{\text{actual}}$ ).

In graph D1-D2 the cleaning speeds are shown in relation to the filter fineness (cleanliness information according to ISO 4406:1999). The values are recorded by laboratory methods and they may be influenced by environmental conditions (such as continuous additional introduction of dirt on running systems, high water content, etc.).

All characteristic curves (see graphs D1-D2) relate to a **reference oil volume** of 180 l and a **nominal volume flow** of 15 l/min.

The following formula should be used to convert to the actual oil volume:

$$t_{\text{actual}} = \frac{V_{\text{actual}} \cdot \Delta t}{12 \cdot Q_{\text{nominal}}}$$

$t_{\text{actual}}$  = actual cleaning speed

$\Delta t$  = cleaning speed for oil volume of 180 l

$V_{\text{actual}}$  = volume of oil to be cleaned

$Q_{\text{nominal}}$  = nominal volume flow, see selection chart

For monitoring purposes we recommend the ARGO-HYTOS OPCom which is built in the version FAPC 016 or the oil particle counter PODS *Pro* (Portable Oil Diagnostic System).

## Determining the cleaning speed

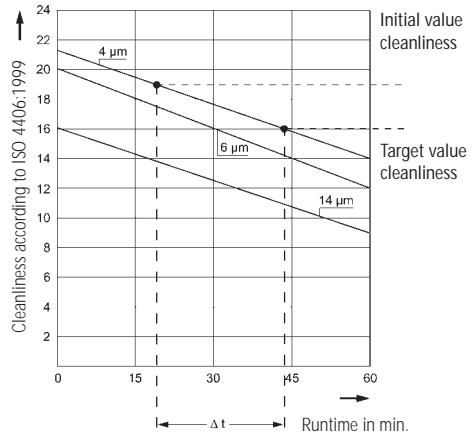

1. Determine the initial cleanliness class and enter it on the graph, e. g. 19/17/14 according to ISO 4406:1999
2. Enter the target cleanliness class on the graph, e.g. 16/14/11 according to ISO 4406:1999
3. Determine  $\Delta t$ , in this case  $\Delta t = 25$  min
4. Insert the value in the formula, where  $V_{\text{actual}} = 350$  l and  $Q_{\text{nominal}} = 16$  l/min

$$t_{\text{actual}} = \frac{V_{\text{actual}} \cdot \Delta t}{12 \cdot Q_{\text{nominal}}} = \frac{350 \cdot 25}{12 \cdot 16} \approx 46 \text{ min}$$

## Curves for cleaning speed as a function of the filter fineness

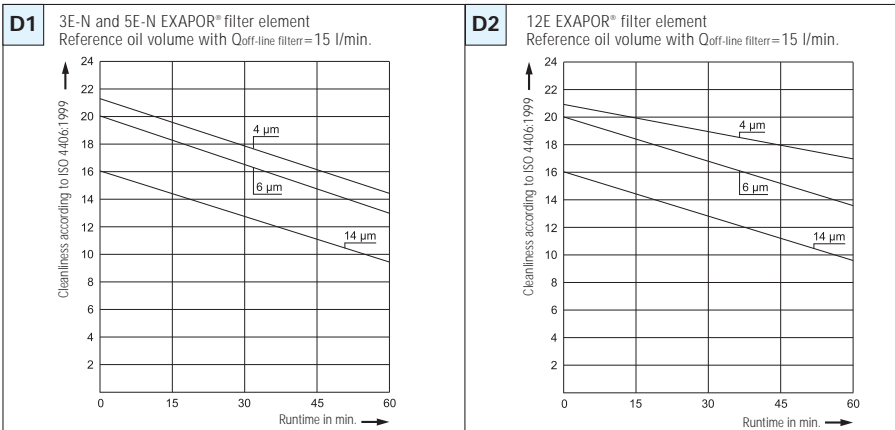

## Filter fineness curves in selection chart

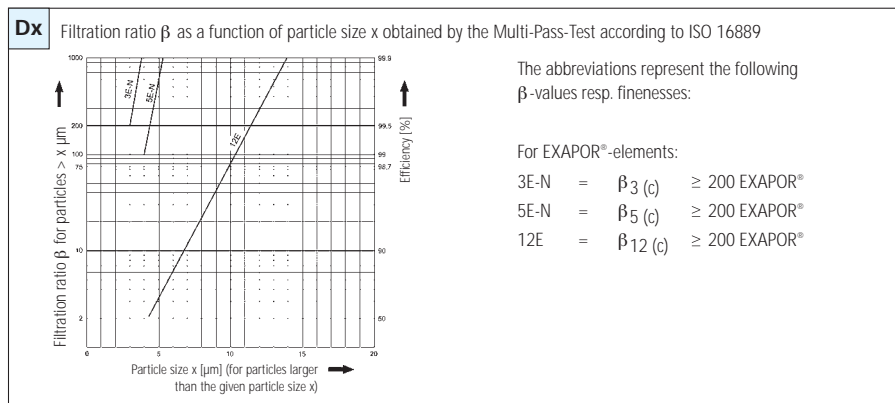

# Characteristics

## Hydraulic connection

Hoses:  
Suction hose NG 32, length 2,7 m, with suction strainer 280 µm,  
pressure hose NG 25, length 2,7 m

## Electrical connection / Electric motor

Electric motor, air cooled fan type  
Cable: length 6 m  
Electro motor types: 1~ 230 V / 50 Hz  
3~ 400 V / 50 Hz  
Type of protection: IP 54  
See selection chart

## Tank capacity

approx. 13 l

## Pump design

Internal gear pump

## Operating and transportation position

Operating position: upright  
Transportation position: upright or horizontal

## Hydraulic fluids

Mineral oil and biodegradable fluids (see info service sheet 00.20).  
Other fluids on request.

## Temperature range of fluids

0 °C ...+65 °C (also see fluid viscosity range).

## Ambient temperature range

0 °C ...+50 °C

## Options

### Water-absorbing filter elements EXAPOR® Aqua

These can be used for short-term water absorption in all standard units. (please inquire)

## Viscosity range

Type	Continuous operation min.	Continuous operation max.	Short-term operation max.
UM 045 / UMP 045 / UMPC 045	15 mm <sup>2</sup> /s	600 mm <sup>2</sup> /s	800 mm <sup>2</sup> /s
UMPC 045	15 mm <sup>2</sup> /s	250 mm <sup>2</sup> /s* 600 mm <sup>2</sup> /s*	800 mm <sup>2</sup> /s

\* Precise determination of the cleanliness class is possible within a viscosity range of 15 mm<sup>2</sup>/s to 250 mm<sup>2</sup>/s.

# Dimensions

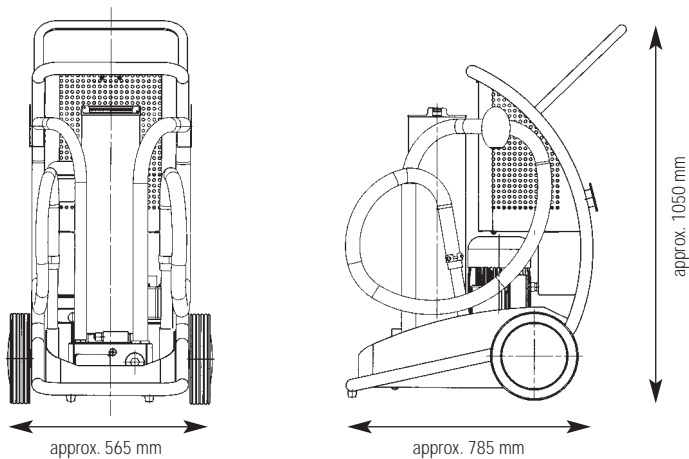

Hydraulic symbol 1 – UM 045

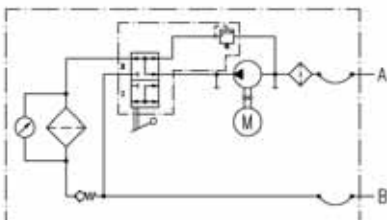

Hydraulic symbol 2 – UMPC 045

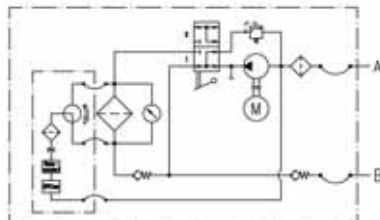

Hydraulic symbol 3 – UMP 045

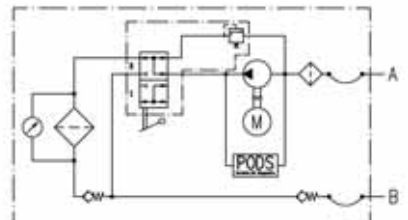

# Advantages at a glance

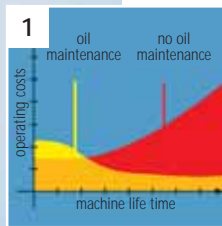

## 1. Economical

Efficiency through ARGO-HYTOS Fluid Management systems. An investment in ARGO-HYTOS systems will be amortized after just a short time, because intervals between services will be longer and machine availability will increase.

## 2. User-friendly filter element change

The filter element can be removed from the housing together with the cover. The dirt retention valve ensures that solid particle sediment is completely removed with the filter element. During operation, the fluid passes through the filter element from the inside to the outside, which eliminates the need for flushing the filter housing.

## 3. Switching functions

The rotary valve is used to switch between the basic modes of operation: "filtering" and "pumping over without filtering".

## 4. Keeping hoses in place

The retainers attached to the sides of the frame secure the hoses in any transport position.

## 5. Compact design

Among the numerous advanced features, listed in the specification of the ECOLINE, compact design was a basic requirement to be met by our team of design engineers. Transporting the ECOLINE in horizontal position, e.g. in the cargo area of a service vehicle, is facilitated by the wheels and the curved design of the frame.

## 6. Unbeatable ergonomics

Superior technology and excellent design are of no use if the service equipment requires great physical effort from the operator. Therefore, ergonomics were of primary importance when the ECOLINE design was conceived.

Owing to its optimized weight distribution, the ECOLINE can be tilted from the standing position with minimum effort. In the tilted position, the ECOLINE can be moved walking upright, removing strain from the back.

# Selection Chart

Order No.  
 Nominal flow rate  
 Filter fineness see diagram Dx  
 Dirt capacity Mi at Q  
 E-Motor operating voltage  
 E-Motor max. operating frequency  
 E-Motor power  
 Length suction hose (lance incl.)  
 Length pressure hose (lance incl.)  
 Viscosity  
 Suction height max.  
 Hydraulic symbol  
 Replacement element order no.  
 Weight  
 Clogging indicator

## ECOLINE basic model - UM 045

UM 045-1553	45 l/min	3E-N	840 g	1-230 V	50 Hz	1,1 kW	2,7 m	2,7 m	15...600 mm <sup>2</sup> /s	2,0 m	1	V7.1560-103	76,5 kg	optical
UM 045-4553	45 l/min	3E-N	840 g	3-400 V	50 Hz	1,1 kW	2,7 m	2,7 m	15...600 mm <sup>2</sup> /s	2,0 m	1	V7.1560-103	76,5 kg	optical
UM 045-1153	45 l/min	5E-N	840 g	1-230 V	50 Hz	1,1 kW	2,7 m	2,7 m	15...600 mm <sup>2</sup> /s	2,0 m	1	V7.1560-03	76,5 kg	optical
UM 045-4153	45 l/min	5E-N	840 g	3-400 V	50 Hz	1,1 kW	2,7 m	2,7 m	15...600 mm <sup>2</sup> /s	2,0 m	1	V7.1560-03	76,5 kg	optical

## ECOLINE with integrated particle monitor OPCom - UMPC 045

UMPC 045-15535	45 l/min	3E-N	840 g	1-230 V	50 Hz	1,1 kW	2,7 m	2,7 m	15...600 mm <sup>2</sup> /s*	2,0 m	2	V7.1560-103	97 kg	optical
UMPC 045-45535	45 l/min	3E-N	840 g	3-400 V	50 Hz	1,1 kW	2,7 m	2,7 m	15...600 mm <sup>2</sup> /s*	2,0 m	2	V7.1560-103	97 kg	optical

Please request our data sheet no. 100.10 for more detailed information on the OPCom particle monitor.

## ECOLINE with oil diagnostic sytem PODS Pro - UMP 045

UMP 045-1553	45 l/min	3E-N	840 g	1-230 V	50 Hz	1,1 kW	2,7 m	2,7 m	15...600 mm <sup>2</sup> /s	2,0 m	3	V7.1560-103	84 kg**	optical
UMP 045-4553	45 l/min	3E-N	840 g	3-400 V	50 Hz	1,1 kW	2,7 m	2,7 m	15...600 mm <sup>2</sup> /s	2,0 m	3	V7.1560-103	84 kg**	optical
UMP 045-1153	45 l/min	5E-N	840 g	1-230 V	50 Hz	1,1 kW	2,7 m	2,7 m	15...600 mm <sup>2</sup> /s	2,0 m	3	V7.1560-03	84 kg**	optical
UMP 045-4153	45 l/min	5E-N	840 g	3-400 V	50 Hz	1,1 kW	2,7 m	2,7 m	15...600 mm <sup>2</sup> /s	2,0 m	3	V7.1560-03	84 kg**	optical

Please request our brochure for more detailed information on the PODS Pro oil diagnostic system.

\* The exact determination of the cleanliness class is possible in a viscosity range of 15 mm<sup>2</sup>/s to 250 mm<sup>2</sup>/s.

\*\* without PODS Pro

Other versions on request.

**Filter elements:** see selection chart

Water-absorbing filter elements EXAPOR® Aqua on request.

**Accessories:** Hose extensions on request.

For the appropriate clogging indicators see datasheet 60.20.

Subject to technical changes.