



Off-line Filters

FNS 060

- With flow control valve
- Operating pressure up to 320 bar
- Nominal flow rate up to 4 l/min

Description

Application

In the high pressure circuits of hydraulic and lubricating oil systems.

Performance features

Protection

against wear: By means of ultra-fine filter elements that meet even the highest demands regarding cleanliness classes and dirt-holding capacity.

Protection against

malfunction: By means of permanent filtration in the off-line circuits excellent cleanliness classes can be achieved.

Special design features

Cover: The cover can be opened without special auxiliary tools. Because of the cover design the filter element can be changed almost without losing any oil. From the high-pressure circuit is cleaned by the fine filter element.

Dirt

retention valve: Ensures that dirt accumulated in the filter is removed together with the element. Settled dirt cannot return into the system.

Filter elements

Flow direction from centre to outside. The star-shaped pleating of the filter material results in:

- large filter surfaces
- low pressure drop
- high dirt-holding capacities
- long service life

Filter maintenance

By using a clogging indicator the correct moment for maintenance is stated and guarantees the optimum utilization of the filter life.

Materials

Filter head: Aluminium alloy

Filter housing: Steel

Cover: Aluminium alloy

Seals: NBR (Viton on request)

Filter media: EXAPOR® - inorganic, multi-layer microfibre web

Accessories

Water-absorbing filter elements (EXAPOR® AQUA) are available on request. Electrical and optical clogging indicators are available on request. Dimensions and technical data see catalogue sheet 60.20.

Characteristics

Nominal flow rate

Up to 4 l/min (see Selection Chart, column 2)

Refers to the medium flow rate of the flow control valve. With selection of the flow control valve a sufficient surplus volume from the high-pressure circuit has to be guaranteed. If necessary the machine manufacturer should be consulted.

Connection

Threaded port according to ISO 228 or DIN 13.

Sizes see Selection Chart, column 6 (other port threads on request)

Filter fineness

3 µm(c)

β-values according to ISO 16889

(see Selection Chart, column 4 and diagram Dx)

Dirt-holding capacity

Values in g test dust ISO MTD according to ISO 16889

(see Selection Chart, column 5)

Hydraulic fluids

Mineral oil and biodegradable fluids
(HEES and HETG, see info-sheet 00.20)

Temperature range

- 30 °C ... + 100 °C (temporary - 40 °C ... + 120 °C)

Viscosity at nominal flow rate

- at operating temperature: $v < 35 \text{ mm}^2/\text{s}$
- as starting viscosity: $v_{\text{max}} = 1200 \text{ mm}^2/\text{s}$

Operating pressure

Max. 320 bar

(max. 5 bar without flow control valve)

Minimum inlet pressure at the flow control valve: 10 bar

Mounting position

Vertical, connection port at the bottom

Diagrams

Δp -curves for complete filters in Selection Chart, column 3

D1 Flow volume as a function of the differential pressure at the flow control valve at $v = 35 \text{ mm}^2/\text{s}$

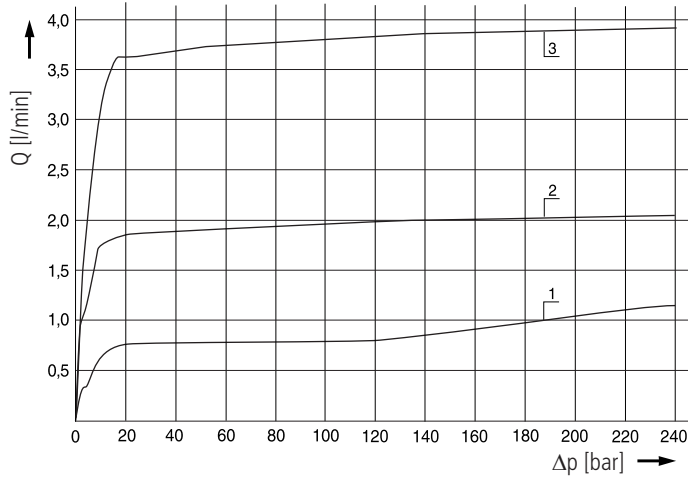

Filter fineness curves in Selection Chart, column 4

Dx Filtration ratio β as a function of particle size x obtained by the Multi-Pass-Test according to ISO 16889

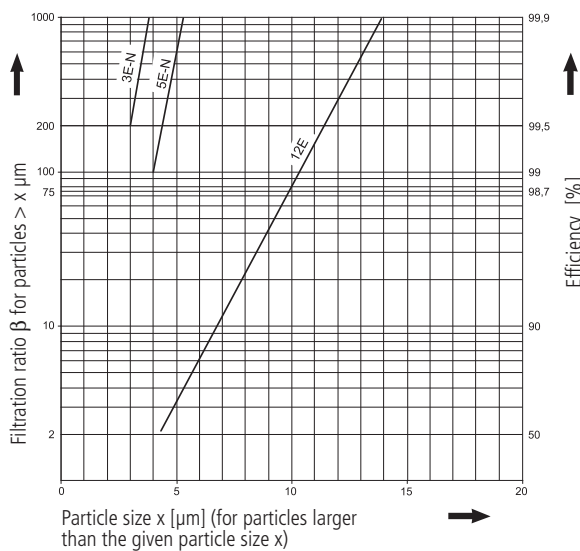

The abbreviations represent the following β -values resp. finenesses:

For EXAPOR®-elements:

3 E-N = $\beta_{3(c)} = 200$ EXAPOR®
5 E-N = $\beta_{5(c)} = 200$ EXAPOR®
12 E = $\beta_{12(c)} = 200$ EXAPOR®

For special applications, finenesses differing from these curves are also available by using special composed filter material.

Dimensions

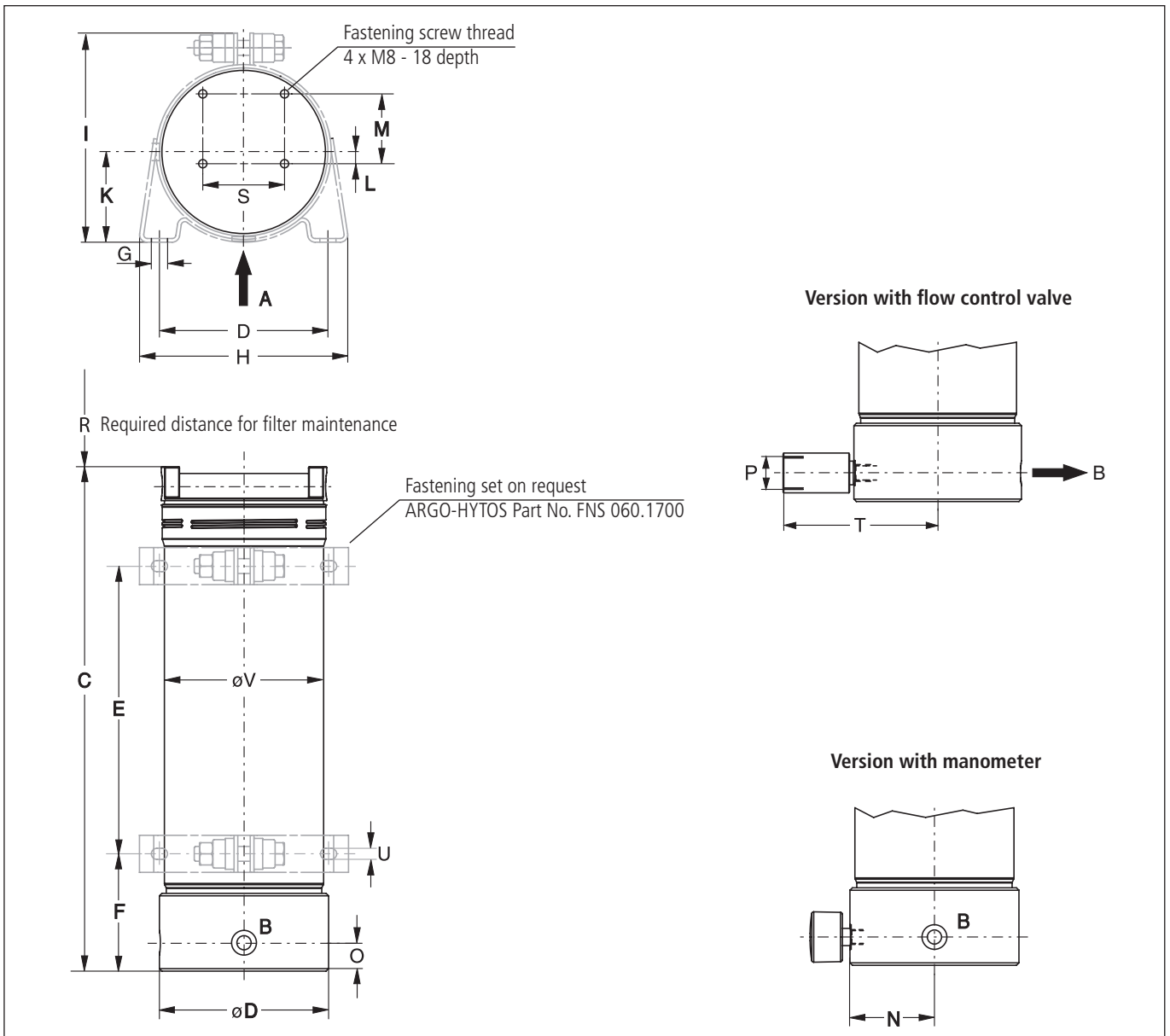

Measurement

| Type | A / B | C | D | E | F | G | H | I | K | L | M | N | O | P | R | S | T | U | V |
|---------|-----------------|-----|-----|-----|----|----|-----|-----|----|-----|------|----|----|-----------------|-----|----|-----|---|-----|
| FNS 060 | G $\frac{1}{4}$ | 410 | 136 | 233 | 95 | 12 | 170 | 169 | 73 | 9,5 | 56,5 | 67 | 23 | G $\frac{3}{4}$ | 300 | 66 | 124 | 9 | 128 |

Symbols

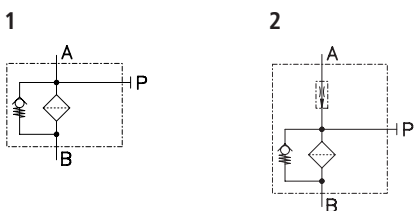

Spare Parts

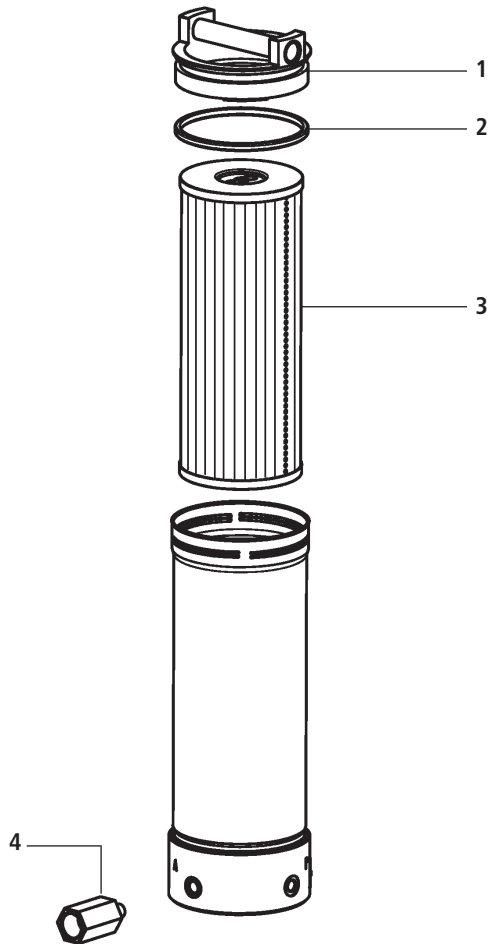

| Pos. | Designation | Part No. |
|------|--------------------|---------------------|
| 1 | Cover | FNA 008.1250 |
| 2 | O-ring | N007.1175 |
| 3 | Filter element | see Selection Chart |
| 4 | Flow control valve | see Selection Chart |

The functions of the complete filters as well as the outstanding features of the filter elements assured by ARGO-HYTOS can only be guaranteed if original ARGO-HYTOS spare parts are used.

Quality Assurance

Quality management according to DIN EN ISO 9001

To ensure constant quality in production and operation, ARGO-HYTOS filter elements undergo strict controls and tests according to the following DIN and ISO standards:

| | |
|---------------------|--|
| DIN ISO 2941 | Verification of collapse/burst resistance |
| DIN ISO 2943 | Verification of material compatibility with fluids |
| DIN ISO 3724 | Verification of flow fatigue characteristics |

| | |
|------------------|---|
| ISO 2942 | Verification of fabrication integrity (Bubble Point Test) |
| ISO 3968 | Evaluation of pressure drop versus flow characteristics |
| ISO 16889 | Multi-Pass-Test (evaluation of filter fineness and dirt-holding capacity) |

Various quality controls during the production process guarantee the leakfree function and solidity of our filters.

Our engineers will be glad to advise you in questions concerning filter application, selection as well as the cleanliness class of the filtered medium attainable under practical operating conditions.

Illustrations may sometimes differ from the original. ARGO-HYTOS is not responsible for any unintentional mistake in this specification sheet.



We produce fluid power solutions

ARGO-HYTOS GMBH · Industriestraße 9 · D-76703 Kraichtal

Tel: +49 7250 76-0 · Fax: +49 7250 76-199 · info.de@argo-hytos.com · www.argo-hytos.com